

JUL-T28 单压力传感器



■特点与用途 Features&Applications

- ▶ 中空设计，压式承载
- ▶ 合金钢材料，形变小
- ▶ 采用高精度电阻应变式原理，动态响应频率高
- ▶ 主要用于压装、千斤顶、锚杆张力等领域的力值检测及自动控制系统

■传感器受力图 Force diagram of sensor

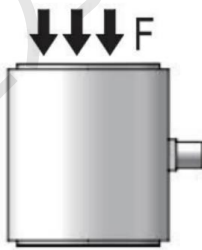

■传感器接线图 Sensor wiring diagram

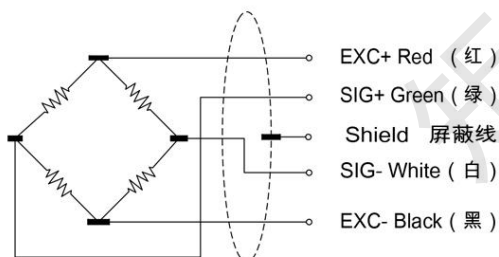

技术参数 Technical specifications		
额定量程	Capacity	5-50T (可选)
输出灵敏度	Rated output	1.5±0.2mV/V
零点输出	Zero balance	±0.02mV/V
非线性	Non-linearity	0.5%F.S
滞后	Hysteresis	0.25%F.S
重复性	Repeatability	0.25%F.S
输入电阻	Input impedance	600 ~ 800Ω
输出电阻	Output impedance	600 ~ 800Ω
绝缘电阻	Insulation	≥5000MΩ/100VDC
激励电压	Recommended excitation	5 ~ 15VDC
温度灵敏度漂移	Temp.effect.on output	0.05%F.S./10°C
零点温度漂移	Temp.effect.on zero	0.05%F.S./10°C
工作温度	Operation temp range	-20 ~ 80°C
安全超载	Safe overload	150%
极限超载	Ultimate overload	200%
防护等级	IP Class	IP65
电缆尺寸	Cable size	Φ5x3000mm
材质	Material	合金钢

外形尺寸 External Dimension

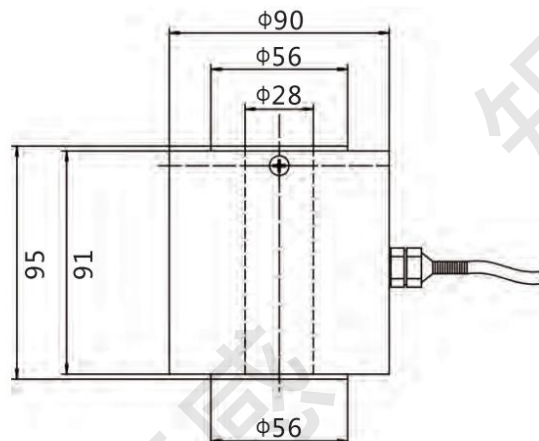

量程(T) 5 10 20 30 50